

# S 36 X

Truck-mounted concrete pump



Vertical reach		35.20 m
Concrete output	max.	161 m <sup>3</sup> /h
Pressure on concrete	max.	85 bar



RECORD BREAKING ENGINEERING

# The S 36 X from SCHWING

## The benchmark for reliability

With its proven technology and main components developed and manufactured by SCHWING, the S 36 X ensures maximum reliability so there are no surprises - even when operating high pump power at low engine speed. The legendary ROCK valve, famed for its robustness and dependability, provides unmatched low operating and maintenance costs. And when it is time for a new SCHWING concrete pump, the high resale value makes it easier to say goodbye.

# S 36 X Truck-mounted concrete pump

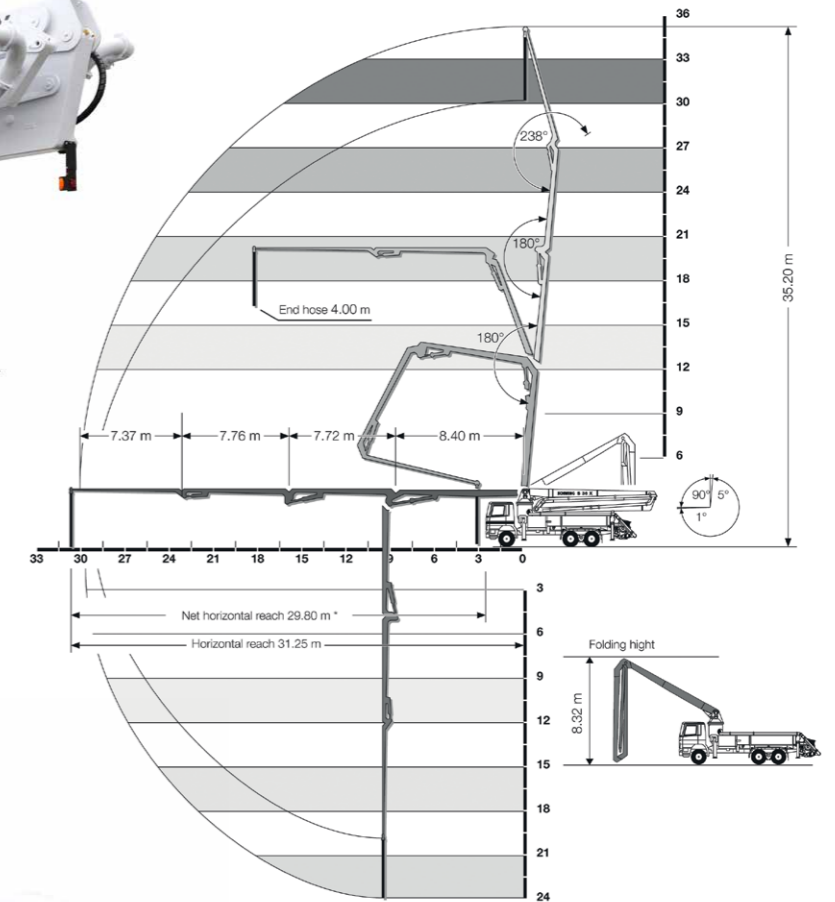

\*mounted on Mercedes-Benz

### Boom

The turret can be rotated 365° in either direction and the tip section can rotate 238° meaning that even the most demanding placement situations can be mastered effortlessly. And the robust construction ensures a long service life.



### Pump kit

The SCHWING control block provides full hydraulic switching of the ROCK and differential cylinders. This ensures outstanding reliability even in difficult operating conditions and makes servicing the system a breeze.



### Open hydraulic system

The open hydraulic system of the S 36 X converts the engine power efficiently into pump power with little loss. Thus, the usual practice output rates can be realized with a fuel-saving engine speed below 1000 rpm.



### Outriggers

The unique combination of front X and rear H outriggers results in a uniquely small footprint. The support legs are designed to withstand the rigours of daily life on the building site - thanks to the protected piston rods and internally laid hydraulic lines.



### Concrete valve

The legendary low wear ROCK valve with its optimal geometry for low-friction concrete flow ensures low service and operating costs. Being fast and easy to clean, the S 36 X is quickly ready for the next job.



### Supply control

The water box can be filled and emptied, and the water pump, agitator, spray hose, high pressure jet wash and compressor, all controlled via the new standardised supply control. This is the standard for all SCHWING truck-mounted concrete pumps for greater clarity and ease of operation.



### Remote control SC 30

The light weight, easy to use and comfortable SC 30 helps minimise fatigue, allowing the operator to focus on the job for extended periods. The powerful batteries guarantee an operating time of at least 8 hours.



### VECTOR control

The machine operator can inspect machine data, operating conditions and settings on S 36 X, changing various parameters, all through the intuitive VECTOR control. The integrated diagnostic system ensures safe operation and also reminds the operator when maintenance is necessary.





## S 36 X Truck-mounted concrete pump

# Technical data

Performance				
Pump kit		P2023-110/75	P2023-110/75	P2025-120/80
Drive	l/min	535	636	535
Delivery cylinders	mm	230 x 2,000	230 x 2,000	250 x 2,000
Concrete output max.	m <sup>3</sup> /h	136	161	136
Pressure on concrete max.	bar	85	85	85
Stroke rate max.	1/min.	27	32	23
Concrete valve		M-ROCK (Option: B-ROCK)	M-ROCK (Option: B-ROCK)	B-ROCK
Hydraulic system				
Design		open system		
Hydraulic tank	l	370		
Boom		36 R		
Delivery line		DN 125		
Length of end hose	m	4.00		
Vertical reach	m	35.20		
Reach depth	m	24.00		
Horizontal reach	m	31.25		
Net horizontal reach	m	29.80 (mounted on Mercedes-Benz)		
Number of boom sections		4		
Height of joints (supported)	m	4.00 / 12.4 / 20.1 / 27.9		
Slewing range		2 x 365°		
Folding height	m	8.32		
Support				
Outrigger width, front	m	6.21		
Outrigger width, rear	m	5.70		
Outrigger load, front	kN	190		
Outrigger load, rear	kN	150		

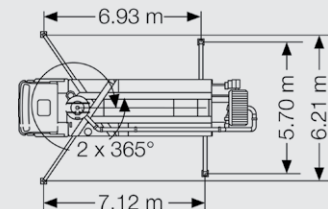

SCHWING concrete pumps. Efficiency as standard.



**SCHWING**  
**Stetter**

SCHWING GmbH  
Heerstrasse 9-27 · 44653 Herne, Germany  
Phone +49 23 25 - 987-0 · Fax +49 23 25 - 72922  
www.schwing-stetter.com · info@schwing.de

Stetter GmbH  
Dr.-Karl-Lenz-Strasse 70 · 87700 Memmingen, Germany  
Phone +49 83 31 - 78-0 · Fax +49 83 31 - 78 275  
www.schwing-stetter.com · info@stetter.de

Subject to technical and dimensional modifications. Illustrations are non-binding. The exact standard specification, the scope of delivery and the technical data are detailed in the offer.